



# FROST TOP DROP-IN

Models FTB-1, -2, -3 FTB-S2, -S3

Hatco Drop-in Frost Tops keep prechilled beverages, snacks, hors d'oeuvres and side dishes cool and ready to serve

## FLEXIBILITY

The Hatco Frost Top units hold full size sheet pans and other flat-bottom serving containers, helping to keep food products cool and fresh. Available in one-, two- and three-pan models as well as two- and three-pan slim configurations to best fit any buffet line.

For easy and flexible installation, the condensing unit may be rotated 90° or 180° (movable in some models). The electronic adjustable temperature control can be mounted to either side of the condensing unit or remotely up to four feet (1219 mm) from the unit.

## QUALITY

The following features assure the finest performance for years to come:

- Accommodates full-size and half-size sheet pans.
- Units include a 1" (25 mm) NPT drain (excluding FTB-1) and refrigeration system.
- The condensing unit, mounted on the center of the unit, rotates 180° (movable in some models).
- Electronic adjustable temperature control available to mount on either side of the condensing unit or remotely mounted up to 4 feet from the unit (cannot be mounted over the condensing unit).
- Long, flexible refrigerant line (ability to pullout condensing unit) for service.
- Lighted On/Off rocker switch.



Model FTB-2 with accessory full size sheet pans

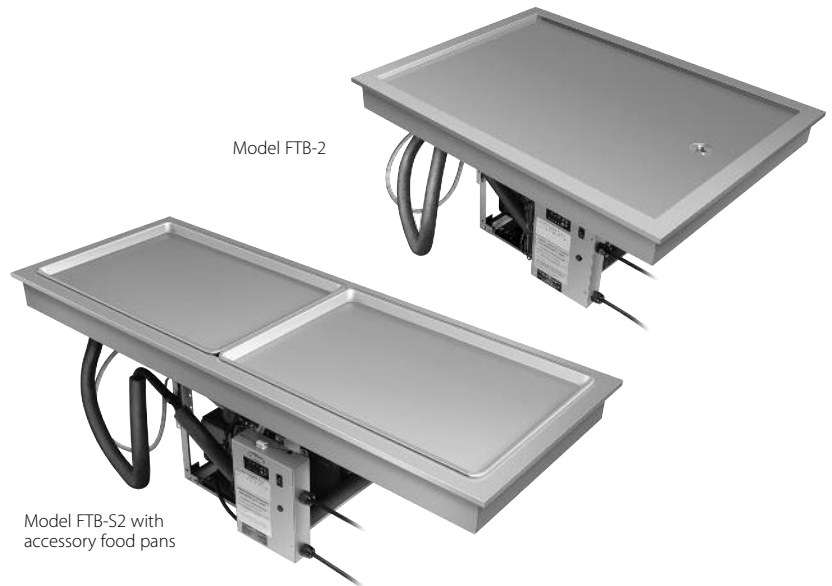

Model FTB-S2 with accessory food pans

## Ordering Instructions

Please specify the following with each order:

- Desired Voltage:** 120V, single volt only
- Number of Full-Size Sheet Pans Accommodated:**  
1-, 2-, or 3-pan as rectangular sheet pans with a Slim or Standard configuration
- Drain** – 1" NPT drain for FTB-2, FTB-3, FTB-S2, FTB-S3 only (drain plumbing to be installed per local codes)

- Insulated** on sides and bottom (environmentally-friendly insulation used throughout)
- Mounting Style** (All units are top mounted only):
- Agency** – UL, C-UL, NSF 7 Component
- Electronic Control Assembly** can be mounted on either side of the condensing unit or remotely mounted up to 4 feet from the unit (cannot be mounted over the condensing unit)

## Countertop Cutout Dimensions

Model	Minimum Width	Maximum Width	Minimum Depth	Maximum Depth
FTB-1	19.44" (494 mm)	20.125" (511 mm)	27.44" (697 mm)	28" (711 mm)
FTB-2	37.375" (949 mm)	38" (965 mm)	27.31" (694 mm)	28" (711 mm)
FTB-3	55.375" (1407 mm)	56" (1422 mm)	27.31" (694 mm)	28" (711 mm)
FTB-S2	53.31" (1354 mm)	54" (1372 mm)	19.44" (494 mm)	20.125" (511 mm)
FTB-S3	79.19" (2011 mm)	79.875" (2029 mm)	19.44" (494 mm)	20.125" (511 mm)



PARTS AND ON-SITE LABOR GUARANTEED FOR ONE YEAR. AN OPTIONAL FIVE-YEAR EXTENDED PARTS ONLY WARRANTY ON THE COMPRESSOR IS AVAILABLE UPON REQUEST.



HATCO CORPORATION P.O. Box 340500 Milwaukee, WI 53234-0500 U.S.A.  
(800) 558-0607 • (414) 671-6350 • Fax (800) 543-7521 • Int'l. Fax (414) 671-3976  
www.hatcocorp.com • E-mail: equipsales@hatcocorp.com

Form No. FTB Spec Sheet

Printed in U.S.A.  
August 2011



# FROST TOP DROP-IN

Models FTB-1, -2, -3 FTB-S2, -S3

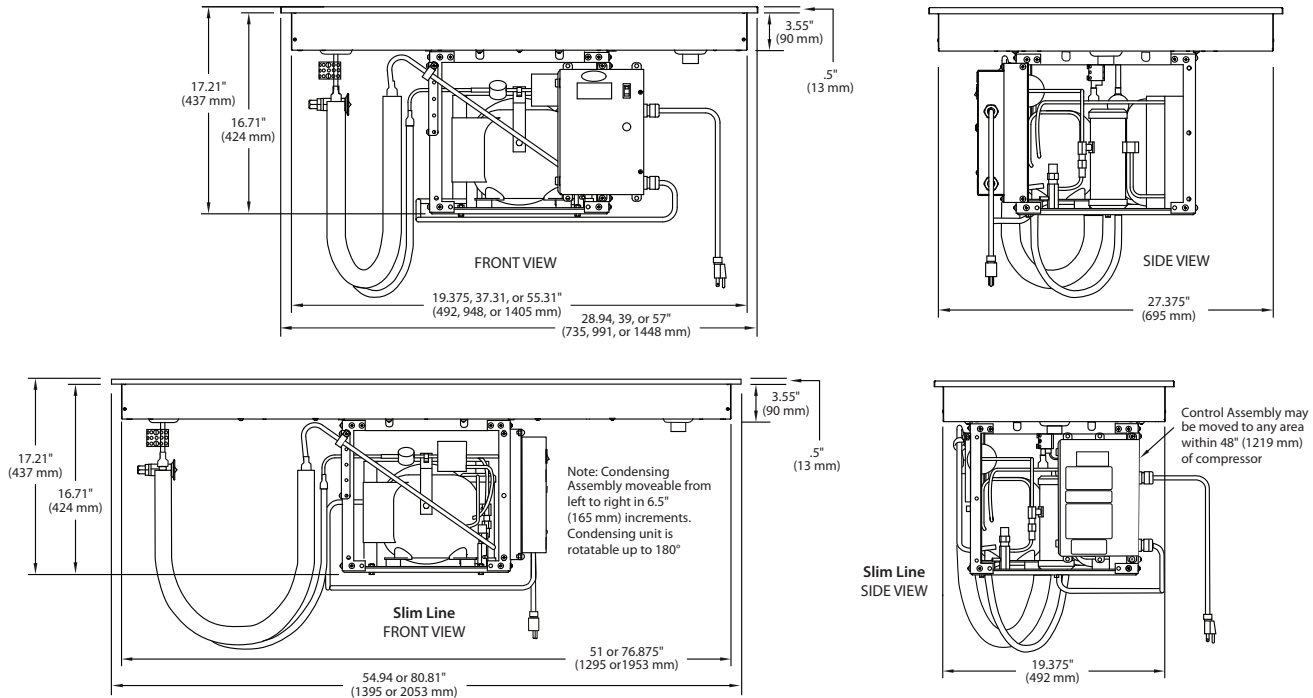

## SPECIFICATIONS

### Frost Top Drop-In

Model*	HP	Volts	Watts	Amps	Shipping Weight†
FTB-1	1/4	120	804	6.7	149 lbs.(68 kg)
FTB-2	1/4	120	804	6.7	169 lbs.(77 kg)
FTB-3	1/4	120	804	6.7	189 lbs.(86 kg)

### Frost Top Drop-In Slim

Model*	HP	Volts	Watts	Amps	Shipping Weight†
FTB-S2	1/4	120	804	6.7	184 lbs.(84 kg)
FTB-S3	1/4	120	804	6.7	214 lbs.(97 kg)

\* Model number indicates number of full-size food pans unit will accommodate.  
All units: R404A refrigerant.

† Shipping weights are approximate.

## DIMENSIONS

FTB-1: 21.06"W x 28.94"D x 17.21"H (535 x 735 x 437 mm).

FTB-2: 39"W x 28.94"D x 17.21"H (991 x 735 x 437 mm).

FTB-3: 57"W x 28.94"D x 17.21"H (1448 x 735 x 437 mm).

FTB-S2: 54.94"W x 21.06"D x 17.21"H (1395 x 535 x 437 mm).

FTB-S3: 80.81"W x 21.06"D x 17.21"H (2053 x 535 x 437 mm).

## Electronic Control:

May be field mounted on either side of the condensing unit or remote mounted up to 4' (1219 mm) from unit. May not be mounted over the condensing coil

## VOLTAGE

120V, single phase (uses NEMA5-15P)

## PLUG CONFIGURATIONS

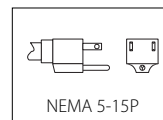

## OPTIONS (NOT FOR RETROFIT)

- Five-Year Extended Parts Only Warranty on Compressor

## ACCESSORIES

- Full-size sheet pan
- Half-size sheet pan

## PRODUCT SPECS

### Drop-in Frost Top

The Drop-In Frost Top shall be a Model ... as manufactured by the Hatco Corporation, Milwaukee, WI 53234 U.S.A.

With 24/7 parts and service assistance (U.S. and Canada only),

the Frost Top shall be rated at ... watts, ... volts and be ... inches (millimeters) in overall width. It shall utilize R-404A refrigerant and consist of aluminized steel housing, electronic temperature control, condenser unit, compressor, and flexible refrigerant lines.