

Item \_\_\_\_\_

**CURVED GLASS  
NON-REFRIGERATED  
BAKERY CASE  
MODEL ECGD-50  
ECGD-59  
ECGD-77**



*Curved-glass styling with presentation and value in mind without sacrificing performance.  
Cases are available in lengths of 50", 59", and 77".*

**STANDARD FEATURES**

- Curved glass.
- Adjustable white wire shelves, 3 tiers, can also be tilted.
- Tempered tilt-out front glass.
- Glass ends and doors.
- Removable sliding rear doors, shelf lights, shelf supports, and shelves.
- Top light and shelf lights.
- Steel base construction, textured black powder coat finish.
- Stainless steel top and sides.
- White display deck.
- Light switch.
- UL Safety and UL Sanitation Listed.
- Cord and plug.

# ELEMENTS CURVED GLASS NON-REFRIGERATED BAKERY CASE

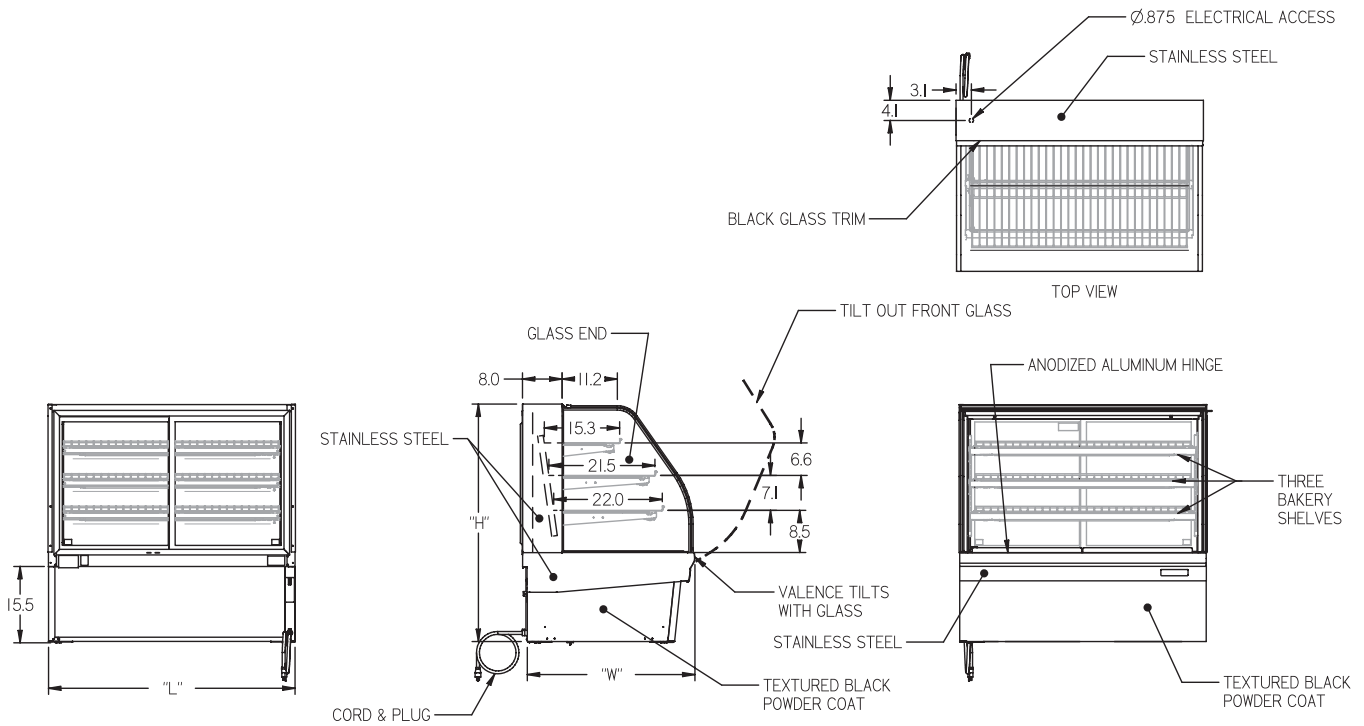

## SPECIFICATIONS:

Model	Dimensions L W H	Shipping Weight (lbs)	Electrical 120/60/1
ECGD-50	50.13" x 35.31" x 48"	500	1.5 AMPS
ECGD-59	59.13" x 35.31" x 48"	535	1.5 AMPS
ECGD-77	77.13" x 35.31" x 48"	715	1.5 AMPS

- Due to continuing engineering improvements, specifications are subject to change without notice.



**Look to Federal for Innovative Merchandising**



*The Signature of Quality®*

**Federal Industries  
A Standex Company  
215 Federal Avenue  
Belleville WI 53508-9201  
Phone: 800-356-4206  
Fax: 608-424-3234  
Email: [geninfo@federalind.com](mailto:geninfo@federalind.com)  
Web Site: [www.federalind.com](http://www.federalind.com)**