

# Champion®

The Dishwashing Machine Specialists

Project \_\_\_\_\_

Item No. \_\_\_\_\_

Quantity \_\_\_\_\_

UL-100 UNDERCOUNTER

## STANDARD FEATURES

- Pumped drain
- Door safety switch
- Low-water tank heat protection
- Built-in detergent, rinse-aid, and sanitizer dispensing pumps
- Wash pump, 1-Hp motor
- Fill and dump
- Electric tank heater
- Upper & lower interchangeable wash/rinse spray arms
- Top mounted controls
- Stainless steel top and side panels
- Single phase connection
- Stainless steel construction
- One year parts and labor warranty

## UL-100

Low Temperature  
Undercounter  
Dishwashing Machine



**NEW!**



## OPTIONS & ACCESSORIES

- 1-RDT Dish Table** Durable, heavy-gauge stainless steel dish table with sink, stand-pipe drain, removable scrap screen holder, drain-board, backsplash and lower storage cabinet. Sprayhose is optional. See 1-RDT catalog sheet) Specify right hand or left hand sink.
- Additional Dish Racks**
- 17" Stand**  
Stainless Steel
- 6" Leg Stand**
- 17" Storage Cabinet**

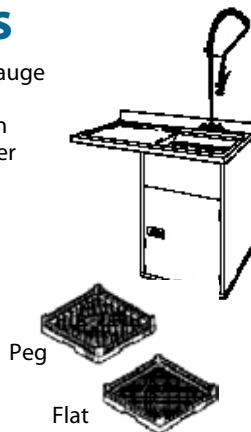
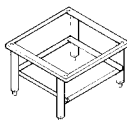

## SPECIFIER STATEMENT

Specified unit will be Champion model UL-100 undercounter low temperature dishwashing machine with built-in detergent, rinse-aid, and sanitizer dispensing pumps.

Features 141 second total cycle, 1 Hp pump motor, fill and dump, pumped drain. Constructed of stainless steel. 1 year parts and labor warranty.

Champion Industries, Inc.  
P. O. Box 4149, Winston-Salem, NC 27115  
Tel: 336/661-1556 Fax: 336/661-1979  
[www.championindustries.com](http://www.championindustries.com)

# UL-100

Low Temperature  
Undercounter  
Dishwashing Machine

# Champion<sup>®</sup>

The Dishwashing Machine Specialists

Dimensions shown in inches

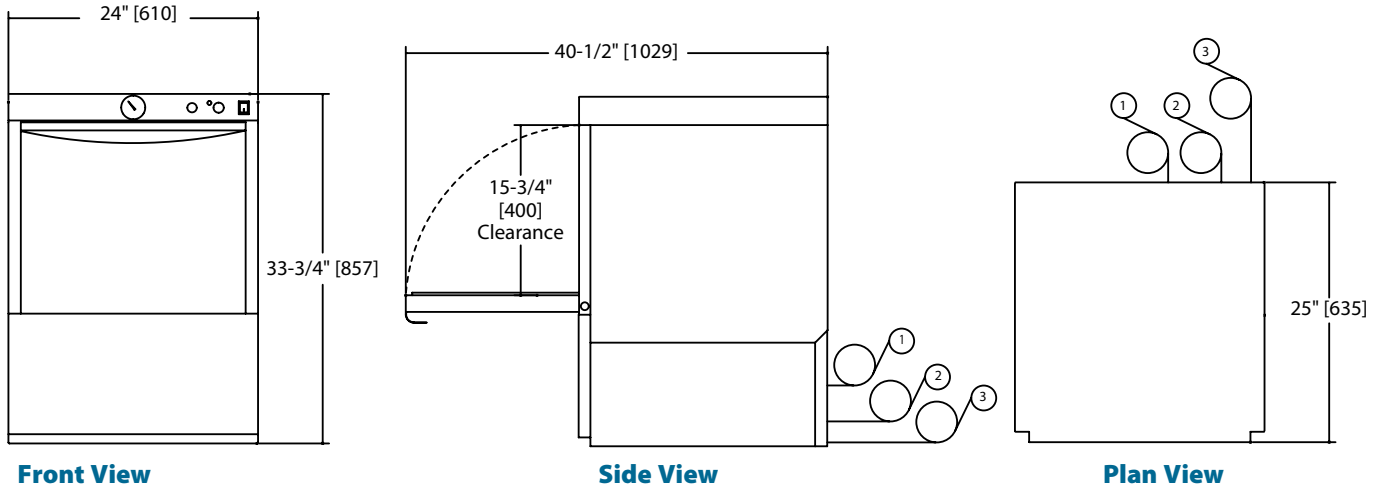

Utilities	
<b>1 Electrical</b>	115/60/1; 12-amp draw; to be fused at 15 amp. 4 ft. plug-in cord supplied.
<b>2 Water connection</b>	140°F/60°C minimum hot water connection; 6 ft. long, 1/2" I.D. flexible fill hose with 3/4" hose connector. Flow pressure: 25-95 psi.
<b>3 Pumped Drain</b>	5/8" I.D. flexible reinforced hose, 6 ft. long. Max. drain flow 15 US gpm. Max. drain height 3 ft.

	Uncrated	Crated
<b>Height*</b>	33-3/4"	39-1/2"
<b>Width</b>	24"	25"
<b>Depth</b>	25"	25-1/2"
<b>Ship Wt. lbs/kg</b>	153	173

\* Front leveling feet provided.

**Warning** Plumbing and electrical connections should be made by qualified personnel who will observe all the applicable plumbing, sanitary and safety codes and the National Electrical Code.

## SPECIFICATIONS

<b>Capacity</b>	
Racks per hr. (NSF rated)	21
<b>Motor horsepower</b>	
Wash	1
<b>Water consumption</b>	
U.S. Gal. per hr. (Max. use)	38.4
U.S. Gal. per rack	1.8
<b>Temperatures °F/°C</b>	
Wash	140/60
Rinse	140/60
<b>Heating</b>	
Tank heat, electric (kW)	.75
<b>Time cycle in seconds</b>	
Wash	90
Rinse	26
Drain/fill	25
Total cycle	141
<b>Standard 20" x 20" rack complement</b>	
Dish	1
Open	1